

User Manual

Radio Zwo4 HS12



2,4 GHz Frequency Band • 12 Channels • Softkeys • Maximum Compatibility

ServoNaut



Introduction

Congratulations on your purchase of the Zwo4 HS12 und thank you for choosing a Servonaut product.

This manual will give you important information and useful tips for your new radio. Please read all chapters attentively and keep the manual to consult at a later time.

Please note, that this manual refers to the **software version 2.3.**

In case you have questions please contact us via Mail sender@servonaut.de or look for support in our Servonaut Support-Forum:

www.servonaut.de/forum



Enjoy your new HS12!

The Servonaut Team

Watch out for the following symbols:



Caution

With this symbol we mark **crucial information** for you.



Tip

Helpful tips are indicated with this symbol.

[.....] Softkeys

The softkeys of your radio that are labeled in the display depending on their function are shown with squared brackets.

Contents

Specifications HS12 / delivery contents.....	6
Safety instructions.....	7
1. Tips: The Difference to Model Flying	8
2. The Radio	10
3. Quick Start: The First Steps	11
4. Enter Names	12
5. Telemetry Show data, adjust alarms.....	13
6. Level Switches Two functions for softkeys and joysticks.....	14
7. Mixer Functions One control for several servos.....	15
8. Light Sets Special functions.....	17
9. Model Quick Select	19
10. Main Menu Swap channels and controls.....	20
10.1 Menu Model Managing Models.....	22
10.2 Menu Receiver Binding.....	23
10.3 Menu Multiswitch Nautic-, Multiswitch-, Multiprop function	24
10.4 Menu Radio Basic settings.....	25
10.5 Menu Trim Trim the joysticks.....	26
10.6 Menu Control Control type, Mixer, Control assignment.....	27
10.7 Menu Control Info	31
10.8 Menu Servo Servo channels, Channel type	32
10.9 Menu Channel Info	36
11. ServoNaut MultiBus	37
12. Instructions for the Pistenking Kingpad	38
13. Instructions for the Tamiya MFC-01	39

14. Instructions for Robbe Superlichtset	40
15. Instructions for the ScaleART Truck Light Board	41
16. Instructions for the Wedico MF2	42
17. Instructions for using Multiswitch Decoder	43
18. Tips for Mounting the Receiver	44
19. Tips for Mounting ESCs and Light Sets	45
20. Tips & Tricks	46
21. SD Card	47
22. Software Update	48
23. Upgrade to 3D Joysticks	49
24. Troubleshooting	50
25. Glossary	51
Liability and Warranty / Disposal Instructions	53
Conformity declaration	54
Your notes	55

Typical Applications:

• Fifth wheel lock, <i>Chapter Quick Start</i>	11
• More than 6 special functions, <i>Chapter Level Switches</i>	14
• Excavator with track drive, <i>Chapter Level Switches</i>	14
• Excavator with grab, <i>Chapter Level Switches</i>	14
• Dual Rate, <i>Chapter Level Switches</i>	14
• Mixer for controlling the rpm of a hydraulic pump, <i>Chapter Mixer</i>	15
• Cross mixer for steering a tracked vehicle, <i>Chapter Mixer</i>	15
• Emergency off, <i>Chapter Mixer</i>	15
• Two steering servos with different travel radius, <i>Chapter Mixer</i>	15
• Fast Trim, <i>Chapter Mixer</i>	15
• Dual Rate, <i>Chapter Mixer</i>	16

Specifications HS12

Stick control channels	2 levels 4 each / 6 each with 3D joysticks
Keyboard control channels	2 levels 6 each
Usable receiver channels without multiswitch	12
Usable channels with multiswitch decoder in the model	11 + 8
Resolution proportional channels / multiswitch channels	2048 steps / 256 steps
Receiver per model master / slave	1 / any number
Number of servos, one softkey/stick can control	up to 3
Number of controls, that can be mixed to one servo	any number
Telemetry (standard with all Zwo4 receivers)	Battery supply voltage, receiver voltage
Display - nonreflecting, backlit	128 x 64 pixel, 70 x 35 mm
Prozessor / Model memory	32 Bit Freescale Coldfire / 15
Frequenzy / power / standard	2,4 GHz / 10 mW / 802.15.4
Battery / endurance	2 Ah 4,8 V Eneloop NiMH / approx. 8 hours
Dimensions / Weight	222x178x55 mm / ca. 830 g

Delivery contents

- Radio incl. battery
- Charging cable
- SD Card
- Instruction manual
- DisplayCARD cable

Safety instructions

- The Zwo4 radio is not licensed for flying models.
- Only use the radio for controlling unmanned vehicles and if no living thing is in danger.
- If you are making adjustments always place the model so it can't drive accidentally or damage the servos.
- Charge the battery only with the specified charging currents, use a suited charger for NiMH batteries designed for model vehicles. *See chapter Quick Start - Battery Charging*
- Check electronic or mechanic connections in your model regularly.
- Check how your model reacts if there is bad reception by turning the radio off. The model should not drive on its own. If it does anyway it is probably because of the ESC - please use high quality ESCs with protective functions.
- Protect the radio from humidity - otherwise errors may occur.
- Avoid using your radio in extreme temperatures - it may damage the LCD display.
- Clean the surface with a soft cloth - do not use an acid detergent.

1. Tips: The Difference to Model Flying

The Zwo4 radio is designed for driving model vehicles and is different than radio systems you may know for flying. To make the change easy for you here are the main differences:

Easy control

The more controls, channels and functions there are the harder it gets to navigate through the menus with a rotary knob or mini joystick. The Servonaut HS12 makes it easy: Use the softkeys which are labeled in the display. In addition the four colored menu buttons above the display are shortcuts for important functions.

Two levels of functions

All joysticks and softkeys can have two functions, you switch between them with the level switches above the joysticks (standard version without 3D sticks).

Multiswitch

Using a multiswitch to have more channels available is common, mostly to control light sets or if many servos need to be controlled.

The Zwo4 radio offers maximum compatibility and works with all systems based on standards of Robbe/Futaba und Graupner/JR. See *chapter Multiswitch*

Assign names

You can not only assign a name to each servo channel, you can also give each control a different name that is shown in the menus. You can even choose a name separately for left and right for each control because one control often has two functions e.g. horn and starter.

Trim

The trim - the adjustment of the center position for joystick channels - is less often used for driving model vehicles than for flying. Therefore with the HS12 the softkeys are also used to adjust the trim settings, see [Menu] > [Trim]. Alternatively you can use a softkey pair or the second level of a joystick. See *chapter Mixer Functions - Quick Trim*

Sliders and rotary knobs

You won't find any on your HS12 because they can make it difficult to switch between different models. The second level of joystick controls is much more practical for drive sets.

For setting values like the idle speed of a pump you can use a softkey pair. The set values stay the same even if you switch to a different model.

Mixer

Radios for model flying use a variety of preset mixer functions (not useful for vehicles). The Zwo4 radio offers a universal and clear concept.

Each control can operate up to three servo channels - one servo channel can be controlled by any number of controls.

All necessary settings are available for the controls so there is no need for a special mixer menu. See *examples in chapter Mixer Functions*

Dual Rate (Travel adjustments)

If you want the control travel to be switchable you can use the level switches. This way you can make extensive adjustments because all settings and mixer functions can be switched. See *chapter Mixer Functions - Dual Rate*

Mode (Control assignments)

With the Zwo4 radio you can choose freely which function is assigned to which control.

For a quick change use the settings under [Menu] > [Swap control]. It even allows you to switch the function of a joystick with that of a softkey pair.

Switches and buttons

They are not upgradeable. Instead **the radio has six universal softkey pairs** that can be labeled in the display. Each pair relates to one servo channel. Because of the level switches there are 2 x 6 controls available. With the control type you can choose if it acts as a button, momentary switch, three way switch, a combination or thanks to a hydraulic simulation as a proportional control.

Fail Safe

With radios for flying each channel can have a fail safe position which is activated if the connection between radio and receiver is bad. This way for example the ESCs stop. Premise is that the positions are correctly adjusted - which often is not the case. Therefore the Zwo4 setup makes it easy for you and cuts all signals to the ESCs if there is bad reception. This method is very secure because it works without further adjustments and with almost all common ESCs.

2. The Radio

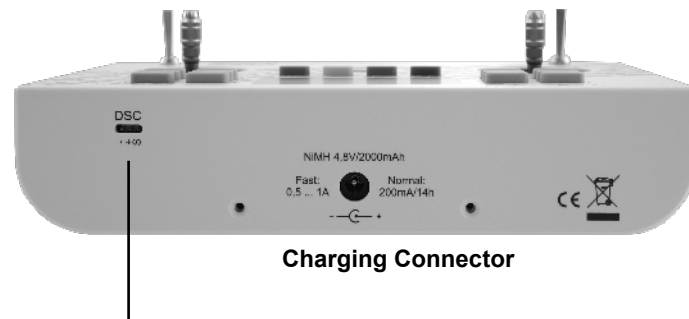
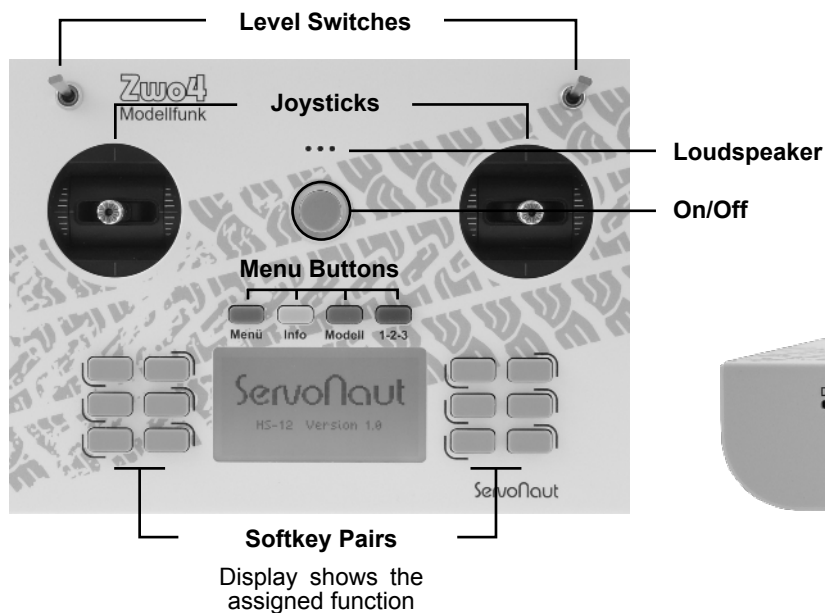

Colored Menu Buttons

Green button:

Main menu - here you find all submenus for controls, servos etc.

Yellow button:

Shows telemetry data

Red button:

Model quick select

Blue button:

Turns the page in the menus

DSC and DisplayCARD Connector

Via the DSC connector a receiver and up to two servos can be connected for testing. Attention: It is directly connected to the battery and does not switch off with the radio. So do not forget to unplug the receiver cable.

For the DisplayCARD function see page 21 of the manual.

3. Quick Start: The First Steps

Charging the battery

Your Zwo4 radio has a NiMH battery with 4 cells and 4,8 V. There are two ways to charge it: a quick charge and a normal charge.

- **Quick charge:** Adjust your battery charger to NiMH and the charging current to 0,5 or 1A. It takes 2 to 5 hours to charge. Do not leave the radio unattended.
- **Normal charge:** We recommend a charging current of 200 mA for normal charge. It takes 14 hours. If the radio stays connected to the charger longer it is not dangerous.



Caution: You need a special type of charger.

Choose the language

You can change the menu language from German to English with [Menu] > [Sender] > [1v2] > [DEU/ENG].

New Model

Go to the Model menu with [Menu] > [Model] > [New Model].

Choose the template MC19 or F14 depending on your favorite layout for the joysticks. See *chapter Menu Model - Channel Assignment*

Set a name for your model. If you don't choose one the radio shows „Model“ and the model number instead.

Choose light set (optional)

If you have a standard light set in your model you can choose a template in the next step with [Light set]. See *chapter Light Sets for details*

With [OK] back to the main menu.

Bind the receiver

Follow the instructions of the receiver manual and put it in bind mode. Then press [Receiver] and [Bind] on the radio. The receiver flashes green. Follow the receiver manual.

Set up special functions

If you want to set special functions for the softkeys and channels 5 to 12 you have to assign the servo channels to the controls.

Example:

Fifth wheel plate lock on channel 5

- Press [Menu] > [Control] and then a key of the softkey pair you want to use e.g. upper right.
- Press [Type] and choose the channel type [Switch - +].
- To assign a channel to a control go to the second menu page with the blue button [1v4].
- Press [Change] and choose [x5 Servo] in the channel menu.
- By pressing [Test] you can switch to the operating screen to test if the fifth wheel plate lock works. Press one of the menu buttons to get back to the control menu.
- Press [OK] a few times to get back to the operating screen.
- You can adjust the direction of the servo rotation and the endpoint with [Menu] > [Servo] > [x5 Servo]. Save a name for the channel e.g. fifth wheel.
- Press [Menu] > [Control] and then the key of the softkey pair you want to use to get to the control menu. Here you can assign a name separately for the left and right key e.g. Open and Close.

4. Enter Names

If there are many controls and channels you lose track easily. Therefore with the Zwo4 radio you can name not only the servo channels but each control individually. Because one control often has two functions e.g. horn and starter you can save two names - for left and right. If you only want one name for both just save one for [Name left/down].



Tip: Always assign a name, a short one at least, to make the handling easier - e.g. S22 for the ESC channel. You always find the naming option in the submenus for controls, servo, radio and model.

Menu Buttons

[OK] Green

Back to the superordinate menu - your input will be saved

[Reset] Red

Deletes whole name

[<-x] Yellow

Deletes last character

[A-a-1] Blue

Selection capital letter, small letter, number/special character

Press the keys once or repeatedly to insert numbers or letters. With [OK] you confirm your input and get back to the menu.

5. Telemetry Show data, adjust alarms

Your Servonaut Zwo4 receiver measures the BEC respectively receiver supply voltage and also the driving battery voltage. All measured values are transmitted to the HS12 radio via telemetry.

In the operating screen press the yellow info button to see the values. Special feature: The Zwo4 radio shows it for **up to four receivers** at the same time - the data for the active model and also for three models in stand-by.

For BEC and supply voltage you can set an alarm value for each model with [Menu] > [Receiver] > [BEC threshold] and [Bat threshold].

6. Level Switches Two functions for softkeys and joysticks

You can **assign two functions** to all softkey pairs and joysticks - **switchable with the level switches**. One control element can have function on level 1 and additional on level 2a or 2b - not both at the same time.

- Choose the level on which you want to activate a function with a level switch (level 1, level 2a or level 2b). If both level switches are in the center position the main level (level 1) is active.

 **Caution:** Make sure that not one of the level switches is in the upper position if you want to adjust the main level. See *chapter Menu Control*

- If you want to adjust level 2a or level 2b, move the left (2a) or right (2b) level switch in the upper position.
- Start the controls menus with [Menu] > [Controls] and move/press the control you want to use.
- Before you make adjustments activate the control with the button [active].
- Now you can also adjust the function for level 2a or 2b. See *chapter Menu Control*
- If you do not want the control to have a function on this level deactivate it again by pressing [active].

Typical applications:

- **More than 6 special functions:** Assign the most used functions to the softkey pairs of the main level (level 1) and the lesser used on level 2a or 2b.
- **Excavator with track drive:** Assign the joysticks according to Euronorm on the main level (level 1). On level 2a or 2b you can additionally assign one joystick for steering the track drive. See *chapter Mixer Functions*
- **Excavator with grab:** Assign the joysticks according to Euronorm on the main level (level 1). On level 2a or 2b you can additionally assign one joystick for steering the grab.
- **Dual Rate for switchable servo travel:** If you want the travel of a control switchable you can do it with the level switches and a mixer. First move/press the control for the first function and adjust it accordingly. Then actuate it again together with the level switch for the second function. Or you can use the Control Copy with [Menu] > [Control Copy]. Choose the same mixer channels for each variant. You can adjust them separately.

To make things clearer when using multiple functions or in particular the 3D-stick, the active level is shown in the middle of the display.

For the main level a '1' is indicated.

For the levels 2a and 2b an 'a' or a 'b' is shown respectively.

Horn	Starter	Indicator
Gearshift	1	Hazard light Rob. d/4
Fog light	MM4-S2	Park light Low beam

Operational view of active main level

7. Mixer Functions

One control for several servos

The Zwo4 radio offers a universal and clear concept: **Each control element can control up to three servo channels - one servo channel can be controlled by any number of control elements.** All necessary settings are available as presets with the controls, therefore there is no special mixer menu.

If you assign a few controls to one servo, the servo channel type defines how they are mixed. See *chapter Servo - Channel Type*

Typical applications:

- **Mixer for controlling the rpm of a hydraulic pump:** Choose the servo channel type [Pump -0→] or [Pump 0→→] for the channel that is connected to the speed controller (ESC) of the pump (channel type depending on your ESC, see chapter *Menu Servo*). For all channels that control hydraulic valves choose the type [Valve]. For the assigned controls the 1. assignment should operate the hydraulic valve, 2. assignment the pump.

By changing the rate [Rate down], [Rate up] or [Rate left], [Rate right] you adjust how much the pump rpm increases when operating the hydraulic valve. Do not forget to switch the speed controller with teach-in function off and back on. Set 'Idle' to a value so that the pump just starts running.

- **Cross mixer for steering a tracked vehicle** with separate motors for left/right and two ESCs: Choose channel type Motor for left and right ESC channel.



Tip: Give them significant names e.g. Left and Right.

Choose the control type [Normal] for the control channel (throttle) for driving forwards and backwards. Assign the 1. assignment to the channel for the left motor and 2. assignment to the right motor. If you accelerate now (throttle up) both tracks should drive forward. If not switch the direction of rotation for the servo channels with [Reverse]. For the steering control left/right also choose the control type [Normal]. The 1. assignment should be assigned to the left motor, the 2. assignment to the right motor. Only for the right motor adjust the efficiency rate [Rate right] to -100% and the [Rate left] to +100%. You can further improve the driving by setting the driving control function [Expo] to -20%, slow down the steering with [Filter] and decrease [Rate left / right].

- **Emergency off** - useful if several functions need to be shut off with the push of a button e.g. drive and pump. Choose the control type **[Emerg. off]** for the softkey pair you want. You can connect up to three servo channels with the assign-

ments of these softkeys. If you press [Emerg. off] all three channels react according to their channel type. See *chapter Servo - Channel Type*

- **Two steering servos with different travel radius:** Choose the channel type [Servo] for both steering servos.



Tip: Assign names to both channels, e.g. Front and Rear.

Set the right direction of rotation in the channel menu with [Reverse] for both servos. Choose the control type [Normal] for the steering controls. For 1. assignment choose the channel for front steering, for 2. assignment the channel for rear steering. Adjust [Rate right] and [Rate left] for each servo.

- **Fast Trim:** If you often need trimming for a function you can use a control for it. Choose the control type [Slider <--->]. Assign the mixer output 1 of this control to the servo channel you want to use and lower the rate for the servo channel. You can also assign trim to the second level of a control and trim by using the level switch.
- **Dual Rate** - for switchable servo travel: If you want the travel of a control switchable you can use level switches or mixer. Actuate the control one time for the first variant and make the settings.

Actuate the control a second time together with the level switch for the second variant or use the function copy control at [Menu] > [Copy control]. Choose the same channels for both mixer outputs. You can adjust the variants individually.

8. Light Sets Special functions



Caution: If you select a light set template all adjustments you made for the light controls and mixers before are reset.

Light set with multiswitch function

Some of the common light sets need an additional multiswitch or nautic module in the radio. With the Servonaut HS12 there is no need for upgrading - the **necessary channel addition is already built-in**. The radio supports Robbe/Futaba as well as Graupner/JR - choose the servo channel 7 or 8. Connect the light set to one of these channels. With the green menu button [Menu] > [Multiswitch] you get to the adjustment menu. See *chapter Menu Multiswitch*.

For a quick start there is a list of common presets. Use presets at [Menu] > [Model] > [Light set]. The light sets use the servo channel 8 for the multiswitch - you may need to replug the channel 8 in the receiver.



In the radio you can't switch channels 7 and 8 if one of them has multiswitch function.

Light set without multiswitch function

Some light sets aren't controlled via multiswitch channels but one or two normal servo channels. Connect the light set to the channels you want, normally channels 5 to 12.

For a quick start there is a list of common light sets with presets at [Menu] > [Model] > [Light set]. Choose EN for the english presets.

Servonaut mini light sets

For mini multiswitches and mini light sets from Servonaut you can choose between **three options**:

1. Control with joysticks (standard)

- Press [Menu] > [Control] and move one joystick. With [Reset] you can delete all old adjustments. With [Reverse] you can swap the joystick direction if necessary.
- To assign a channel to the control press the blue button to get to page [2v4].
- Press [Change] and choose the receiver channel that mini multiswitch or light set are connected to. Leave all other adjustments for control and servo channel as they are.
- We recommend assigning a [Name] to the channel e.g. ML4. You can also name

the servo channel in the servo channel menu for an even better overview.

- Press [OK] a few times to get back to the operating screen.

2. Control with one softkey pair

- Press [Menu] > [Control] and press one key of the pair you want to use.
- With [Reset] you can delete all settings for this control. Switch the softkeys with [Reverse] if necessary.
- To assign a channel to the control go to page [2v4] with the blue menu button.
- Press [Change] and choose the receiver channel connected to the mini multiswitch or mini light set. Don't change any other settings for the control and servo channel.
- We recommend assigning a [Name] for each softkey, e.g. Indicator L and Indicator R. You can also name the channel in the servo channel menu, e.g. ML4 for the light set, for an even better overview.
- Press [OK] a few times to get back to the operating screen.

3. Control with two softkey pairs for the Servonaut ML4

- **Indicator:** Press [Menu] > [Control] and press one key of the pair you want to use for the indicator. With [Reset] you can delete all settings for this control. Switch the softkeys with [Reverse] if necessary.

- To assign a channel to the control go to page [2v4] with the blue menu button.
- Press [Change] and choose the receiver channel connected to the mini multi-switch or mini light set.
- In the menu [Type] choose the control type [Impuls] on the second page.
- Set the [Length] to 0,5s. Don't change any other settings for the control and servo channel. Assign a [Name] to each softkey, e.g. Indicator L and Indicator R.
- **Warning Signal, Light:** Press [Menu] > [Control] and press one key of the pair you want to use for the warning signal and light.
- With [Reset] you can delete all settings for this control. Switch the softkeys with [Reverse] if necessary.
- To assign a channel to the control go to page [2v4] with the blue menu button.
- Press [Change] and choose the receiver channel connected to the mini multi-switch or mini light set.
- In the menu [Type] choose the control type [Impuls] on the second page.
- Set the [Length] to 0,2s. Don't change any other settings for the control and servo channel. Assign [Names] to each softkey, e.g. Warn and Light.
- You can also name the channel in the servo channel menu, e.g. ML4 for the light set, for an even better overview.
- Press [OK] a few times to get back to the operating screen.

Setting the channel assignment

The light set templates use preset servo channels. If you want the light set to use other servo channels you can change it with [Menu] > [2v2] > [Swap channel]. This function is not available for light sets with multi-switch function.

Change the softkey assignment

For the light set templates you can adjust the softkey assignment with [Menu] > [2v2] > [Swap control].

9. Model Quick Select

With the Zwo4 radio you can **switch between up to four ready to start models.**

Start the Quick Select Menu with the red menu button. The active model stops. The radio shows all available models that are connected. Choose the one you want to drive.



Tip: The red button functions as an emergency off as well because it stops all active models. Important: Not with all speed controllers - please test the function beforehand when the model is jacked up.

If you press the red button again, a list with all saved models will be displayed and you can choose one from the list.

10. Main Menu

Menu Buttons

[OK] Green
Back to the superordinate menu.

[1v2] Blue
To the next page.

These submenus are part of the main menu:

- Menu **Model**
Manage models
- Menu **Control**
Control, Control types, Mixer
- Menu **Control info**
- Menu **Servo**
- Menu **Channel info**
- Menu **Multiswitch**
- Menu **Trim**
- Menu **Radio**
Basic settings
- Menu **Receiver**
Bind, Telemetry, BEC Treshold, Battery Threshold, Battery type
- Menu **SD Card**
- **Swap control**
- **Swap channel**
- **Menu DisplayCARD**
- **Copy control**

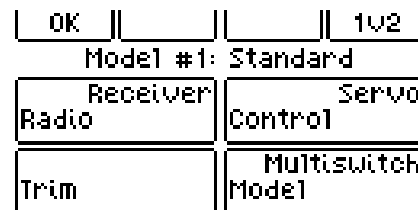

Screenshot Overview Main Menu, page 1

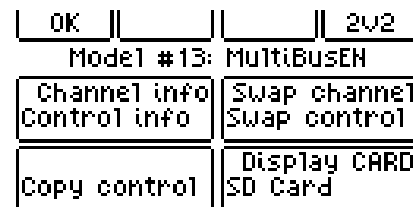

Screenshot Overview Main Menu, page 2

[Swap channel]

With the servo swap you can **swap two connections at the receiver**. All functions and adjustments for these channels are swapped as well. The channel numbers remain. For example servo channel 3 is always the third output at the receiver.

It is possible to swap two channels of a multiswitch or a channel of the multiswitch with a normal channel. There may be a lag because the multi channels work a little slower.

[Copy control]

With the control copy you can copy all settings for one control to another one. If you want to control a function in your model two ways e.g. one time with big deflection and one time with small deflection (dual rate), you can copy the control with [Control copy] to the second level. Adjust the settings and switch between the two with the level switches.

[Swap control]

Here you can swap the function of two controls with each other. Useful to adjust the assignment of keys or to temporarily assign a function to a joystick. Even if you swap a joystick with a softkey pair all settings remain.

 **Caution:** If you didn't assign names to the controls the default names don't change after a control swap because the softkeys are numbered serially with Control 7, Control 8 etc. The settings still change though.

[DisplayCARD]

Activates the DisplayCARD mode. In this mode, a Servonaut module which is connected via cable to the HS12 can be programmed. Modules, which can be programmed by DisplayCARD are marked by a DisplayCARD Logo.



To program a module connect the module via DisplayCARD cable to the radio and call up the menu. Press the right middle or lower keys, in order to select the first menu option.

 **Caution:** The connection to all receivers is deactivated while in DisplayCARD mode. The connection is reestablished after leaving the menu.

Note: Standard servo cables can be used as DisplayCARD cables, if the red wire is removed from at least one plug.

10.1 Menu Model Managing Models

Green Button [Menu] > [Model]

In this menu you can create new models, switch between them or delete them. If you start the menu the active model stops. Special feature: If you create a new model you can choose model template and light set template separately. You can use one of the light set templates and adjust it as you like.

Menu buttons

[OK] Green
Back to the superordinate menu.

Softkeys

[New model]
Create a new model: Choose a model template or copy an existing model.



Caution: Don't forget to bind the model's receiver in the receiver menu of your radio. See *Menu Receiver*

[Light set]
Here you can choose a light set template.

[Select]
Select the model you want to adjust. Not until you leave the menu your radio connects to the model.

[Delete]
Choose the model you want to delete. The model that is active at the moment can't be deleted.

[Name]
Here you can assign a name to each model. If you don't, the radio shows „Model“ with the number instead.

Template F14 - Channel assignment joysticks

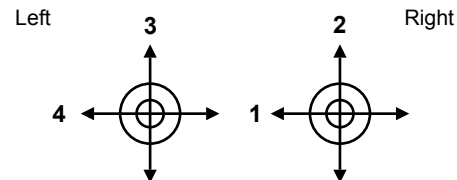

Template MC19 - Channel assignment joysticks

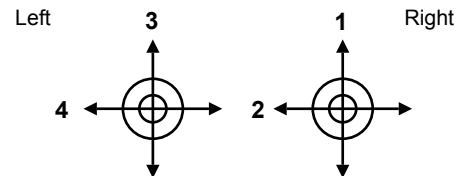

Green Button [Menu] > [Receiver]



Caution: The adjustments always relate to the selected model!

Menu buttons

[OK] Green

Back to the superordinate menu.

[Reset] Red

Deletes all settings on this page and restores the factory settings. The binding with the receiver remains.

[CARD] Yellow

Activates the DisplayCARD Menu so you can adjust the receiver remote controlled. In the CARD Menu you can use the blue button to switch between settings for the master and the slave receiver. This only works for newer Receivers RX9, R6, R4.

Softkeys

[Bind]

By binding **radio and receiver connect**. They kind of exchange numbers once to find each other again in the 2.4GHz frequency band. Only after binding successfully the receiver reacts to the radio.

At the receiver you need to remove or set a jumper and then switch the model on - check the steps according to the receiver manual.

Press the button [Bind] so the radio searches for the receiver. If the search is successful they connect and the number of the receiver is stored in the model memory.

This binding is necessary only once but can be repeated as often as you like e.g. if you put the receiver in a different model.

[BEC threshold]

The Servonaut Zwo4 receivers monitor the **supply voltage of the servos**. If the voltage falls below the preset value there is an alarm. Normally it is set at 4.6 Volt. If it falls lower the receiver or servo supply voltage may be overstrained. To switch the monitoring off press both adjust-softkeys at the same time.

[Battery type]

The Zwo4 receivers can also monitor the **battery supply voltage** if the receiver is connected to the battery - see the receiver manual for more information.

There is an alarm for low voltage as well - the [Battery threshold]. To make the adjustments easier you can select the battery type with the left softkey and the number of cells with the right softkey for [Battery type].

[Battery threshold]

Lets you adjust the threshold for the battery monitoring. Select one of the recommended values with [Battery type] and fine-tune them if you like. To switch the monitoring off press both adjust-softkeys at the same time.

[E4/E6/E9/E18]

Activate this option if you use a Servonaut receiver Zwo4E4, Zwo4E6, Zwo4E9 or Zwo4E18. You can recognize the E9 and E18 receivers because they consist of two parts - a black receiver module with an antenna and a decoder.

10.3 Menu Multiswitch Nautic-, Multiswitch-, Multiprop function on channel 7 or 8

Green button [Menu] > [Multiswitch]

Some of the common light sets need an additional **multiswitch or nautic module** in the radio. Such a module can be used as a channel extension to get more servos in the model or more switching functions. Normally an additional multiprop, nautic or multiswitch decoder is necessary.

With the HS12 this channel extension is already built-in. The HS12 supports systems from Robbe/Futaba als well as Graupner/JR on channel 7 or 8. After each time switching the multiswitch function on/off the receiver needs to be bound again to set the changes. Your radio shows a hint to remind you.

Menu buttons

[OK] Green
Back to the superordinate menu.

[Reset] Red
Deletes all settings on this page and restores the factory settings.

[1v2] Blue
Shows the number of pages and turns to the next one. Page 1 is for channel 7, page 2 for channel 8.

Softkeys

[Channel7] **[Channel8]**
Switches the multiswitch function for the channel on/off (on = black underlined, see screenshot). You can only choose one of the two channels.

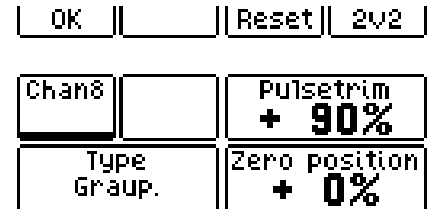

[Type]
Switches between Robbe/Futaba and Graupner/JR system.

[Pulsetrim]
Allows the fine tuning of the impulse length. This adjustment is only an emergency option - contact the Servonaut Team via email at sender@servonaut.de.

[Zero position]
Allows the fine tuning of the impulse length. This adjustment is only an emergency option - contact the Servonaut Team via email at sender@servonaut.de.

10.4 Menu Radio Basic settings

Green button [Menu] > [Radio]

Here you find all **basic settings** for the radio. The HS12 does not have mode settings as known from radios for flying. Instead controls and servo channel can be paired freely.

 **Tip:** Use the advantage to assign names to all controls and servo channels - you will benefit from it.

Menu buttons

[OK] Green

Back to the superordinate menu.

[1v2] Blue

Shows the number of pages and turns to the next one.

Softkeys

[Contrast]

Adjust the display contrast so you can easily read the screen from all angles.

[Light]

Here you can switch the display backlight on/off. Because the supply current is so low we recommend leaving it on all the time.

Furthermore the HS12 supports an automatic switch-off of the backlight in the “operational view”. In order to start this function press both push buttons [Light] at the same time. The display then changes to seconds. This time the background light stays on after switching to operational view. In the menu the backlight is active all the time. Additionally the backlight in the operational view can manually be switched on or off using the blue key. When entering the menu the automatic mode is reactivated.

[3D stick]

If you equipped your radio with 3D sticks you can activate the additional rotary function. The buttons function as level switches - you decide if the push buttons act as momentary or memory switch.

[Alarm]

Vibration, acoustic alarm (beeper) and visual alarm (flashing display light) can be switched on/off separately. Settings apply to all alarms - even the ones controlled by the receiver regarding the model. If the battery voltage falls below the value set for [Battery

alarm] there is always an acoustic alarm, The visual alarm can be set additionally.

[DEU/ENG]

Switches the language between German and English.

[Radio name]

Give your radio a name e.g. your first name.

[Rescan]

Cuts the radio connection off and scans the 2.4 GHz frequency band to connect the receiver again.

10.5 Menu Trim

Trim the joysticks

Green button [Menu] > [Trim]

The Trim of the joystick middle position of the HS12 also works by using the multifunction buttons.

The Trim takes place for all levels separately (1, 2a, 2b). The activated level is shown in the middle of the display (1, a, b).

The Trim values for each model are saved separately. In case it is necessary to switch the Trim or the middle position frequently, this can also be done by a mixing function. See chapter Mixer Functions - Fast Trim

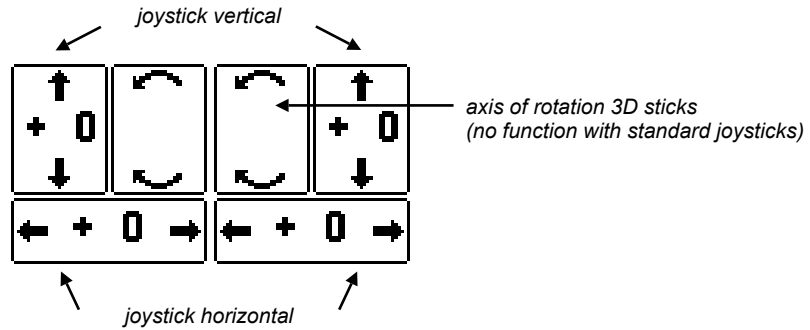

10.6 Menu Control

Control type, Mixer, Control assignment

Green button [Menu] > [Control]

The **two joysticks** and the **2 x 3 softkey pairs** left and right of the display are the controls of your HS12. In the control menu you find all adjustment possibilities and the assignment of the controls to the servo channel outputs of the receiver. The assignment of joysticks and softkeys can be switched and copied. See *chapter Main Menu*

Control Menu

Get to the Control Menu with [Menu] > [Control]. Actuate the control you want.

 **Caution:** The two level switches are active. The level that is currently selected is shown in the display so you don't adjust the wrong control. Thanks to the level switches all controls can be used two ways. See *chapter Level Switches*

After selecting the control you get to the first page of the adjustments.

About the percentages: The final values are affected by the settings in the servo menu. A control that is set to 100 % can be set to cause 125 % deflection in the servo menu. See *chapter Menu Servo - Examples*

Menu buttons

[OK] Green
Back to the superordinate menu.

[Test] Yellow
Temporarily switches back to the normal display and function to test the softkey pairs. To end the test mode press [OK] or [Info].

[Reset] Red
Resets all adjustments on this page to the default factory settings. Press [Reset] a second time to set the control type to normal.

[1v4] Blue
Shows the number of pages and turns to the next one. The control menu has four pages.

Softkeys - different for each control type

[Active]
Only shown when a control is selected for level 2a or 2b. You can activate and deactivate a control with this softkey.

[Name]
Allows you to assign one or two names to the control. If you only save a name for left just this one will be shown. See *chapter Enter Names*

[Reverse]
Swaps the left and right softkey of one pair or reverses the direction of a joystick.

[Type]
With the type you set how the control works and reacts.

[Expo]
A negative expo value reduces the effect of small control movements and allows sensitive steering. A positive expo value increases the effect of small movements. In both cases the end point deflection is the same. Only for the joysticks.

[Filter]
With the filter you can change the reaction speed of a control.

 **Tip:** A filter value about 1.0 is best for realistic steering.

[Runtime]
Only for the control types [Slider <--->] and [Slider <-0->]: This sets the travel time of the control from 0 to 100% deflection and lets you choose how sensitive the function is.

[Time]
For control type [Impuls]: It sets the length of the keystroke that is transmitted.

On pages 2 to 4 of the control menu you can assign up to three servo channels.

 **Caution:** Without assigning channels the control has no function and the model doesn't respond.

[->Channel]

Starts the channel selection.

[Change]

Starts the channel selection to change the assignment.

Caution: If there is a channel assigned already the menu shows the channel name instead of [->channel] and pressing a key starts the servo channel menu of this channel to make adjustments. To delete all channel assignments press [Reset], twice if necessary.

[Dead zone]

Sets the range around the joysticks middle position in which the control value is 0% - that is where the control doesn't react.

[Rate left/Rate down]

Sets how strong the control affects the channel when a left key is pressed or the joystick is moved to the left or down.

[Rate right/Rate up]

Sets how strong the control affects the channel when a right key is pressed or the joystick is moved right or up.

You can set the values for [Left] and [Right] anywhere from -100 to +100%. Press both softkeys together to get to the Quick Select Menu with often used presets.

Your radio has following control types:

- Normal
- Switch - 0 +
- Switch - +
- Switch 1-2-3
- Switch/PushB
- Emerg off
- Slider <--->
- Slider <-0->
- Impulse
- Slider 0--->
- min Impuls
- Prop Threshold

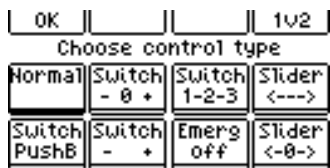

Control types, page 1

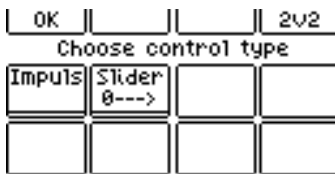

Control types, page 2

Control type [Normal]

Typical use for **joysticks**: **Steering, Throttle**

- Joysticks: They work proportionally from -100% to +100%

Typical use for a **softkey pair**: control functions of a **light set**

- Softkey pair: The left key results in -100% while pressed, the right key in +100%. No key pressed is middle position at 0%.

Control type [Switch - 0 +]

Typical use: Extend and retract **auxiliary gear** or **tilting drive** with the possibility to stop it.

The control has three positions: -100% , 0% and +100% with memory function. It simulates a switch with three positions.

- Joysticks: Shortly actuating in one direction or another switches the control to +100% or -100%. If you actuate it twice it is back in the middle at 0%.
- Softkey pair: Press the key shortly to set the control to +100% or -100%. If you press it a second time it is back in the middle at 0%.

Control type [Switch - +]

Typical use: Fifth wheel lock, differential lock

The control has two positions: -100% and +100%. It simulates a switch with two positions.

- Joysticks: Shortly actuating switches the control to +100% or -100%.
- Softkey pair: Press the left key to set the control at -100%. Press the right key to set it at +100%.

Control type [Switch 1-2-3]

Typical use: Sequential shift for **three-gear gearbox**

The control has three positions: -100% , 0% and +100%. It simulates a sequential gear shift.

- Joysticks: Shortly actuating switches one step after another from -100% to 0 to +100% and back.
- Softkey pair: Press the right key shortly to set the control from -100% to 0 to +100%. Press the left key to set it back step by step.

Control type [Switch/PushB]

Typical use: Functions of a multiswitch light set

The control has three positions: -100% , 0% and +100%. It simulates a switch that is a switch in one direction and a pushbutton in the other.

- Joysticks: Shortly actuating to one side switches the control to -100%, again to 0%. Move it to the other side to set it to 100%.
- Softkey pair: Shortly press the left key to set the control to -100%. Press again to set it to 0. Hold the right key to get +100%. Press [Reverse] to swap the function of both keys - Pushbutton left, Switch right.

Control type [Emerg off]

Typical use: **Immediately switches off** an internal combustion engine, a hydraulic pump or model drive

The control has two positions: Normal and Emergency off. In the Emergency off position the control affects up to three servo channels, different for each channel type. *See chapter Mixer Functions*

- Joysticks: Not useful
- Softkey pair: Press the right key shortly for an Emergency off, all drives stop and are blocked. The left key lifts the blocking.

Control type [Slider <--->]

Typical use: **Hydraulic simulation, swivel drives** of any kind e.g. lowering a ramp, adjusting volume or idle speed, trim

With this control type you can move a servo like it was a hydraulic cylinder moved by a valve. The control works proportionally without steps even if you use a softkey pair.

- Joysticks: Depending on how big the deflection is the control value changes faster or slower. The speed is also affected by the value for [Runtime].
- Softkey pair: The value changes with each key stroke, the speed is affected by the value for [Runtime].

Control type [Slider <0->]

Typical use: **Swivel drives with middle position**

Same as the Hydraulic simulation [Slider <--->] but it stops in the middle position at 0%. Release and actuate the control again to get beyond that point.

Control type [Impuls] (on page 2v2)

Typical use: **Control light sets** *See chapter Light Sets*

 **Caution:** With some light sets e.g. the ML4 short and long key strokes/joystick moves cause different functions. To assign these functions to different softkey pairs your HS12 has the control type [Impuls].

- Joysticks: Not useful
- Softkey pair: Same as control type [Normal] but the values -100% or +100% are set for an adjustable time - no matter if the key is pressed shortly or long.

Control type [min Impuls] (page 2v2)

Typical use: **Control multiswitch light sets** See *chapter Light Sets*

Works like the control type [Impuls] but you can extend the duration of the pulse by holding down the key. The configured duration is thereby a minimal duration. This can be useful for function controlled by a multi-switch module where a minimal length is necessary to activate a function but sometimes a longer period is desired (for a horn for example).

Control type [Prop Thres] (page 2v2)

- Joysticks: Up until the set threshold the control outputs 0%, above it outputs the threshold value proportionally up to $\pm 100\%$. If for example the threshold is set to 50% the output is 0% up until 50% and above it is 51% up to 100%
- Softkey pair: Not useful, acts like control type [Normal]

Control and servo channel assignment (mixer function)

Each control can affect up to three servo channels - one servo channel can be affected by any number of controls.



Caution: You need to assign at least one servo channel to a control otherwise it has no function! If you have selected the model template MC19 the joysticks are assigned to the servo channels 1 to 4 as usual with Graupner.



Caution: Don't assign the same servo channel to one control more than once. Errors may occur!

With the model template FC14 the joysticks are assigned to the servo channels 1 to 4 as usual with Robbe/Futaba. But basically you can choose the assignment as you like.

Make the assignment in the control menu on page 2 to 4 by selecting the servo channel. Press [Reset] to delete the assignment. See *chapter Mixer Functions for examples*

10.7 Menu Control Info

If there are many mixer functions it is easy to lose track which control has an effect on which channel. You can **see in the control info which control is assigned to which channel** and adjust the channel settings.

[Menu] > [1v2] > [Channel info] on page 2

Now actuate the control you want to view.



Caution: The two level switches are active. The level that is currently selected is shown in the display so you don't adjust the wrong control.



Caution: If the control isn't active on this level you get the hint „Control inactive on this level“. *Infos for activating see chapter Menu Control*

The menu now shows all servo channels this control is assigned to as well as the deflection in percent. Press a key of one of the servo channels to get to the settings for this channel.

OK	Test	STOP	S/A
Control: Control 2		53%	
X1:Servo	1	---	
+ 42%			

When entering the menu it is in Test mode (the Test key is highlighted by a dark background). In this mode the radio detects automatically which control element (joystick or softkey) you use and shows the right setting screen.

By pressing the [Test] key you leave the Test mode. The operation of the softkeys now depends on the state of the [S/A] key:

OK	Test	STOP	S/A
Control: Control 2		0%	
X1:Servo	1	---	
+ 0%			

If S (for Servo) is highlighted, pressing one of the softkeys for a servo channel will take you directly to the corresponding servo menu.

OK	Test	STOP	S/A
Control: Control 2		0%	
X1:Servo	1	2. Assignment	---
+ 0%			
3. Assignment		4. Assignment	---

If A (for Assignment) is highlighted, pressing one of the softkeys for an assignment will take you directly to the corresponding page of the control menu. Disabling or changing the assignments for a control is thereby very easily done.

10.8 Menu Servo Servo channels, Channel type

Green Button [Menu] > [Servo]

Servo channels are all the outputs of the receiver. Depending on which Zwo4 receiver you use there are 4, 6, 9 or 12 channels available - your HS12 has 12 channel slots in the menu and always uses the first ones. For example with a 4 channel receiver the first 4 slots in your HS12 are used. The channels are numbered from X1 to X12.

You can activate a multiswitch for the channel 7 or 8. See *chapter Menu Multiswitch*. Then the radio doesn't show the channel number but [MULTI 7/8]. Press [MULTI] to select the channels of the multiswitch. The eight multiswitch channels are named X7a to X7h or X8a to X8h. You can swap them as you like. See *chapter Menu Receiver, function [Servo swap]*

 **Tip:** The normal channels and the channels of the multiswitch have the same settings and even can be swapped with each other. The multiswitch channels react a little slower though.

Channel selection and adjustment

Select the servo channel (= channel of the receiver) you want to adjust with [Channel selection]. After selecting a channel you see the first page of the channel adjustment.

Menu buttons

[OK] Green

Back to the superordinate menu (channel selection).

[Test] Yellow

Switches the test mode on/off. In test mode a connected servo immediately reacts to a key stroke [Left, Right, Center] and moves to the position to make adjustments easier.

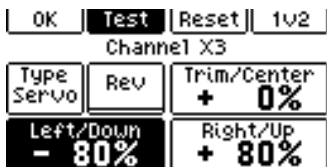

Filled black = Test Mode on. The active position has a dark background.



Caution: If a speed controller is connected to the channel it switches to full throttle when in test mode. So select the channel type [motor] for all channels connected to an ESC to avoid damage. There the test mode is blocked.

[Reset] Red

First key stroke: sets all values to default
Second key stroke: changes the channel type to [servo]

[1v2] Blue

Shows the number of pages and turns to the next one.

Softkeys - different for each channel type:

[Reverse]

Changes the direction of the servo channel - helps to adjust that e.g. while steering the left key [left/down] affects the deflection on the left.

[Type]

Here you select the channel type. It determines all mixer and safety functions for the channel.

[Left/Down], [Right/Up], [Trim/Center]

The maximum deflection prevents that e.g. a servo reaches a mechanical stop and overloads. The values for [Left/Down], [Right/Up] are adjustable between -150% and +150% (Exception pump: here the values are different). The values determine how far the servo moves from one endpoint to the other.

Examples:

- A maximum control deflection of +100% and an endpoint value of 100% equals a servo deflection of 100%.
- A maximum control deflection of +80% and an endpoint value of 100% equals a servo deflection of 80%.

- A maximum control deflection of +100% and an endpoint value of 120% equals a servo deflection of 120%.
- Two controls with a maximum control deflection of +70% mixed (together +140%) and an endpoint value of 120% equals a servo deflection of 120% - the endpoint value limits it.



Tip: Always adjust the mechanics first and only make small adjustments with your radio. If values under 80% seem to be necessary for a servo it is advisable to rethink the steering and place the rod further inwards at the servo. If the deflection causes problems in one direction only you can mount the steering arm a little rotated. Otherwise you lose torque / power!

[Channel name]

Here you can assign a name to each channel. If you didn't name the channel the radio shows the channel type instead.

[Speed <s>] for several channel types

The speed determines how long it takes the servo to move from 0 to 100% deflection. For full servo speed set the value 0,0s. At a value of 3,0s the servo needs about 3 seconds to the endpoint. The servo moves with constant speed not fast at first and then slower like with a filter function of the control.



Caution: The transmission of multi-switch channels is delayed. Some multiswitch decoders slow the servos down as well. The value might not have a visible effect in that case.

Pump lag [Lag <s>] just for channel type [Pump]

The pump lag sets how long a hydraulic pump runs after the last actuation before turning off automatically - the maximum is 30 seconds. With a value below 0 the pump is constantly on (can only be switched off with emergency off).

The radio has following channel types:

- Servo
- Valve
- Sound
- Max
- Motor
- Pump 0→
- Cruise ctrl.
- Pump -0→
- Temp.

Channel type [Servo]

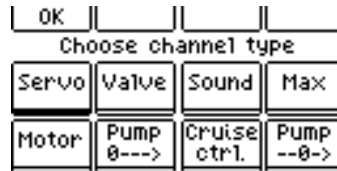

Channel types

Typical use: **Steering**; all channels connected to servos (exception hydraulic valve servo)

Function: You can **adjust left and right full deflection** and the **middle position for a servo**.

Emergency off: The connected servo moves into neutral position (middle).

Mixer function: All controls that affect this channel are added up.

Test mode (yellow button): Yes - see paragraph test, page 32

Channel type [Valve]

Typical use: **Operate valve servos**

Function: Allows **compensation of the valve backlash**

Valve [Backlash]

Hydraulic valves often need a certain deflection to react. With backlash compensation the hydraulic valves react directly even with small control movements.

Mixer function: All controls that affect this channel are added up.

Emergency off: Channel in neutral position

Test mode (yellow button): Yes

Channel type [Sound]

Typical use: **Raise the motor sound rpm** if auxiliary drives are on or you actuate hydraulic valves. (For models with hydraulic or auxiliary drives. For Servonaut Sound-modules choose [Normal] for the channel you operate starter and horn with, not [Sound].)

Function: **Idle speed or full throttle forwards adjustable.** Possibility to set the rpm for a sound module controlled by a servo channel

Mixer function: All controls that affect this channel are added up. *See chapter Mixer Functions*

Emergency off: Channel in neutral position

Test mode (yellow button): Yes

Channel type [Max]

Typical use: **Control light sets MFC-01 und MFC-02**

Function: You can **adjust left and right full deflection** and the **middle position for the channel.**

Mixer function: Takes the maximum value out of all controls that affect this channel. *See chapter Light Sets*

Emergency off: Channel in neutral position

Test mode (yellow button): Yes

Channel type [Motor]

Typical use: **Electronic speed controller (ESC) for the drive motor;** all drives that run forwards and backwards, e.g. spindle drives or a pump that moves forwards and backwards. (Same as channel type [Servo] but without a test mode, for security reasons.)

Function: For an **ESC you can set maximum speed forwards and backwards and the neutral position.**

Emergency off: Channel in neutral position

Mixer function: All controls that affect this channel are added up.

Test mode (yellow button): No

Channel type [Pump 0-->]

For all **ESCs that move motors in only one direction** e.g. flight controllers for brushless motors. Full deflection on this channel is 0% in one direction and +100% in the other, center position +50%. Those controller/motor combinations are often used for hydraulic pumps.

Typical use: **ESC for hydraulic pumps;** all drives that run in one direction only.

Function: For a **pump the idle is adjustable** as well. After the pump lag time (see [Pump lag] page before) the channel activates the value set for [Off].

There is a threshold for both pump types. As long as the excursion on the pump channel is bigger then the threshold, the automatic switch-off is blocked. In case the excursion is smaller then the set threshold, the auto-

matic switch-off is active when the figure is longer steady than the time set in the after-run period.

Emergency off: Channel activates the value set for [Off]

Mixer function: All movements of controls that affect this channel - no matter in which direction - are added up. *See chapter Mixer Functions*

Test mode (yellow button): Yes

Attention if you use the **test mode:** If the maximum is set to +100% the controller switches to full throttle with any key stroke. If you need to teach-in the controller, we recommend the following steps in test mode:

- Set [Off] to 0% and [Maximum] to +100%
- set the controller in teach mode according to its manual (often with a jumper)
- by pressing [Off] and [Maximum] you can transmit the full deflection values to the controller
- press [Off] and then [Test] to leave the test mode
- at first reduce the [Maximum] to 50%
- start the test mode again to adjust [Idle] and [Maximum]. Be careful - the pump starts!

Channel type [Pump -0->]

For all **standard ESCs for forwards/backwards that move a pump in only one direction**. Full deflection on this channel is -100% in one direction and +100% in the other, center position 0%. Only half the range is used - from 0% to +100%. The instructions for channel type [Pump-0->] apply for this one as well.

Typical use: **ESC for hydraulic pumps**; all drives that run in one direction only.

Function: For a **pump the idle is adjustable** as well. After the pump lag time (see [Pump lag] two pages before) the channel activates the value set for [Off].

Emergency off: Channel activates the value set for [Off]

Mixer function: All movements of controls that affect this channel - no matter in which direction - are added up. *See chapter Mixer Functions*

Test mode (yellow button): Yes



Tip: To test this controller/pump combination you can temporarily assign a joystick control to a servo channel.

Channel type [Cruise ctrl.]

Typical use: **Servonaut ESCs with cruise control** e.g. M20+, M24, K products

Function: For servonaut ESCs you can set **maximum speed** forwards and backwards, **brake force** and **neutral position**.

Emergency off: ESC brakes.

Mixer function: All controls that affect this channel are added up.

Test mode (yellow button): No

10.9 Menu Channel Info

When many mixer functions are set it is difficult to keep track which control affects which channel. With the channel info you **can see which controls affects a certain servo channel** and you can adjust the control settings.

Green button [Menu] > [Channel info]

Select one servo channel (= output at the receiver). After selecting you get a list of controls that affect this channel - your radio shows a maximum of 8. With one key stroke you get to the settings for a control. See *chapter Menu Control*

Go back to the overview page with [OK]. One after another you can adjust each control for the servo channel.



Channel info, example - those controls are active for channel x11

11. Servonaut MultiBus

Of course the HS12 supports the functions of the ServoNaut MultiBus in the new Servonaut modules. The chart on your right shows the channel assignment and the arrangement corresponding to the modules. The relevant template in the HS12 is called "MultiBusEN". Unlike the other templates, not all controls are equipped with a "meaningful name" with this template. Since some of the controls are able to operate different functions depending on the module in use, these controls are named with the corresponding channel number. But names can be changed of course. Like all templates, the MultiBus is set on channel 8 of the radio.

The key assignment can easily be adjusted by function [Menu]>[Radio] >[Control swap].

If you want to swap two functions on one pair of keys use [Menu]>[Control] >[Reverse]. Adjust the name if necessary.

Please take a look at the manuals of the modules for more precise descriptions of the functions, e.g. MM4 manual.



Multi-channel	SM7	M24	MM4	ML4
X8a	Starter/Horn			
X8b		Gearshift	Servo output 1 only usable without cruise control	
X8c			Output L1 & S2, wiper function, Servoausgang 2	
X8d		Hazard light	Output S3 not usable Output L4 e.g. high beam	Hazard light
X8e	Volume			
X8f	Tipper/Siren			
X8g		Park/Low Beam		Park/Low Beam
X8h		Indicator		Indicator

Multi-channel assignment with the Robbe/Futaba system

12. Instructions for the Pistenking Kingpad

Your Servonaut radio can **simulate the function of a Kingpad**. We don't recommend connecting an original Kingpad.

The template in your HS12 assumes the **steering servo on channel 1** (common with Robbe/Futaba). If it is not on channel 1 you need to change the channels. Make sure the **full deflection left/right is set to 100% for the steering servo channel**.

As an exception don't use the settings of the servo channel for adjusting the steering servo but the settings for the control (joystick). Set a filter value > 0 for the control for steering to avoid errors of the light set while steering.

For setup the control type [Normal] is preset for the control. The linking with the steering channel remains however. You can only trigger the light functions if the joystick for steering is in middle position.

To calibrate the module you need to press the softkeys of the HS12 in the exact order the Kingpad defines (!) - see the Kingpad manual and the table on the right. Remember that the high beam functions as a warning flash as long as the low beam is off. You can change the softkey assignment with [Menu] > [Control swap].

Two functions on one softkey pair can be swapped with [Menu] > [Control] > [Reverse]. You may need to edit the names manually.



Tip: After setup choose the control type [Impuls] with 0,5s. This avoids unintentional steering movements if you press the softkeys too long.

Kingpad function	matching control rate
Parking light	1
Low beam	9
High beam	8
Worklight front	7
Fog lights	6
Rotating beacon	5
Reverse light	-5
Worklight rear	-6
Indicator left	-7
Hazard light	-8
Indicator right	-9
Special function	-1

13. Instructions for the Tamiya MFC-01

Your Servonaut radio allows you to **control the light and special functions of the MFC-01** with softkeys, trim is not needed. Connect the four channels of the MFC according to the Tamiya manual to the receiver channels 1 to 4. Create a new model and load the **light set template MFC-01EN**.

For this light set the joystick controls and softkeys for gear changing and horn are set to 80% rate, the softkeys for the special functions to 100% and the servo channels 1 to 4 to 125% rate.

The joysticks have 100% travel at the receiver (80% x 125% = 100%) and the softkeys simulate full deflection with additional trim like you need for special functions with the MFC.

Calibrate the MFC as follows:

1. Press a button of the MFC for about 1 second
2. Move the left joystick (throttle) first all the way up then all the way down
3. With the softkeys select the third gear, then second gear, first gear and then second gear again
4. Press the softkeys for horn/support - first right then left
5. Move the right joystick (steering) first all the way to the right then all the way to the left
6. Press a button of the MFC again

- We recommend adjusting the steering servo mechanically only. If the steering trim of the radio is changed after calibration errors may occur with the special functions.
- If a different model is selected (with the red menu button - Modell) the MFC turns the motor sound off.
- The MFC reacts delayed sometimes, press the softkeys a little longer if necessary.
- The softkeys for mode change [Horn Mode] and [Run mode] use the same channel as the gear shift and therefore only work in second gear (middle position).

- The ignition is assigned to both keys of a softkey pair - left and right key have the same function.
- The control [Fifth Wheel] is on servo channel 7 as a default setting.
- The key assignment can be changed with [Menu] > [Swap Control].
- Two functions on one softkey pair can be swapped with [Menu] > [Control] > [Reverse]. You may need to edit the names manually.

14. Instructions for Robbe Superlichtset

Your Servonaut radio enables **new functions with the light set** like turning the indicator off automatically as well as more flexibility in choosing different control types and assigning the softkeys as you like.

- **Channel 8** is preset, **Multiswitch type Robbe** - that can't be changed. If your Superlichtset is plugged in on channel 7 of the receiver replug it to channel 8.
- With the left level switch you can display the trailer functions and the hazard light.
- The control type [Impuls] is set for the indicator right and left with 3s. After a keystroke the indicator flashes for 3 seconds and then turns off automatically. You can adjust the time as you like.
- If you don't want it to turn off automatically you can change the control type to [Normal] (flashes as long as the key is pressed) or the type [Switch -0+] (first keystroke turns the indicator on, the second one off).
- If you want the indicator to react to the steering use the mixer: Select the control settings for the steering and select the servo channel X8h for the 2. assignment.
- For the option servo tractor vehicle and the servo for the fifth wheel coupling the control type [Switch +/-] is set with only two positions left/right. For the servo support trailer the control type [Slider] is

set. You can steplessly operate it. All control types can be adjusted if necessary.

- The control [Horn/Starter] e.g. for a Servonaut sound module is preset to servo channel 7.
- You can easily change the key assignment with the function [Menu] > [Swap control].
- Two functions on one softkey pair can be swapped with [Menu] > [Control] > [Reverse]. You may need to edit the names manually.
- Remember that with the Superlichtset the high beam can only be switched on when parking or driving light is already on.

Multi Channel	Robbe Superlichtset Truck Output	Robbe Superlichtset Function
X8a	Servo	Option servo tractor vehicle
X8b	L5 & L6	Hazard light / Trailer on/off
X8c	L1 & L8	Parking light / Low beam
X8d	L8	Headlight warning flash / High beam
X8e	at Superlichtset Trailer	Servo Support Trailer
X8f	Servo	Servo fifth wheel coupling
X8g	L7 / L3	Front flasher / Fog lamp
X8h	L5 / L6	Indicator left/right

15. Instructions for the ScaleART Truck Light Board

Your Servonaut radio allows **more flexibility with the Truck Light Board** and lets you choose between different control types and the assignment of keys.

For an interference-free operating and model switching we recommend using a Servonaut AN40 remote on/off switch for the power supply in your model.

- **Channel 8** is preset, **Multiswitch type Robbe** - that can't be changed. If your Truck Light Board is plugged in on channel 7 of the receiver replug it to channel 8.
- With the left level switch you can display the trailer functions.
- Most light functions already have a memory function in the Light Board. Therefore the control type [Normal] is set and should not be changed.
- If you want the indicator to react to the steering use the mixer: Select the control settings for the steering and select the servo channel X8h for the 2. assignment.
- For the servo trailer 1 and the servo for the fifth wheel coupling the control type [Switch +/-] is set with only two positions left/right. For the servo trailer 2 the control type [Slider] is set. You can steplessly operate it. All control types can be adjusted if necessary.

- The control [Horn/Starter] e.g. for a Servonaut sound module is preset to servo channel 7.
- You can easily change the key assignment with the function [Menu] > [Swap control].
- Two functions on one softkey pair can be swapped with [Menu] > [Control] > [Reverse]. You may need to edit the names manually.

Radio HS12 Multi Channel	Truck Light Board Output	Truck Light Board Function
X8a	no output	Trailer Off / IR Robbe
X8b	L3 & L11	Fog / Additional headlights
X8c	L10 & L1	Parking light / Low beam
X8d	L2	High beam / Warning signal
X8e	at Trailer Main Board	Servo Trailer 2
X8f	at Trailer Main Board	Servo Trailer 1
X8g	Servo Out	Servo fifth wheel coupling
X8h	L5 / L6	Indicator left/right

16. Instructions for the Wedico MF2

Your Servonaut radio enables **new functions with the MF2** like turning the indicator off automatically as well as more flexibility in assigning the softkeys as you like.

- **Channel 8** is preset, **Multiswitch type Robbe** - that can't be changed. If your MF2 is plugged in on channel 7 of the receiver replug it to channel 8.
- With the left level switch you can display the functions 1 to 6.
- Most light functions already have a memory function in the MF2. Therefore the control type [Normal] is set and should not be changed.
- The control type [Impuls] ist set for the indicator right and left with 3s. After a keystroke the indicator flashes for 3 seconds and then turns off automatically. You can adjust the time as you like.
- If you don't want it to turn off automatically you can change the control type to [Normal] (flashes as long as the key is pressed) or the type [Switch -0+] (first keystroke turns the indicator on, the second one off).



- **Important:** Switching the indicator on with your radio is only possible if the clamp terminal 3 of the MF2 (see manual MF2) is not connected to the steering channel. Otherwise the indicator can only be operated with the steering.
- Output 5 has a double function and switches the IR transmitting diode on/off as well.

- The control [Fifth wheel] is set to servo channel 7, you can change that if you like.
- You can also change the key assignment with the function [Menu] > [Swap control].
- Two functions on one softkey pair can be swapped with [Menu] > [Control] > [Reverse]. You may need to edit the names manually.
- There are different versions of the MF2. See the manual of your MF2 for the detailed functions of the multiswitch channels - your radio HS12 simulates only one multiswitch.

Multi Channel	Wedico MF2 Output	Wedico MF2 Function
X8a	Lighting board front & rear	Hazard light / Warning flash
X8b	Switching channel 3 & 4	Switching channel 3 & 4
X8c	Switching channel 1 & 2	Switching channel 1 & 2
X8d	Motor & Horn	Starter & Horn
X8e	Lighting board front & rear	Indicator left/right
X8f	Switching channel 5 & 6	Switching function 5 (IR) & 6
X8g	Lighting board front & rear	Fog light / Rear fog light
X8h	Lighting board front & rear	Low beam / High beam

17. Instructions for using Multiswitch Decoder

Your Servonaut radio supports a **multi-switch decoder on channel 7 or 8**. The channels are named with lower case letters. If you select the multiswitch function for channel 8 your radio shows channels X8a to X8h instead of X8.

See the table for the assignment of multi-switch channels for common decoders. Most decoders react a little delayed so the servo movements are delayed. You may need to press the keys longer to activate a function.

If you use a light set with multi decoder that the HS12 has no template for we recommend using any template and adjusting it. That is easier than to start from scratch.

In most cases you only need to adjust the multi channel for the controls to your light set. For a first test set the control type to [Normal].

HS12 Multi Channel	Robbe Multi Decoder Switch+Prop	Robbe Multi Switch 16 Decoder	Graupner 2-16K Nautic Expert
X8a	K1	K1	A
X8b	K2	K2	B
X8c	K3	K3	C
X8d	K4	K4	D
X8e	K5	K5	E
X8f	K6	K6	F
X8g	Servo K7	K7	G
X8h	Servo K8	K8	H

18. Tips for Mounting the Receiver

The 2.4 GHz model radio is especially interference-proof but nevertheless: To avoid interference under difficult conditions e.g. events with many radios we have a few tips for mounting the receiver:

- For best reception the last **three centimeters of the receiver antenna** should **point vertically up** and far away from any metals parts or cables.
- For a model with metal driver cabin we recommend placing the last three centimeters of the **antenna through a drill hole outside** or at least placing it in the middle of the cabin.
- Don't kink the **antenna cable**. Carefully lay it in a curve round the corners.
- With ships the higher the antenna is mounted above the water surface the better the range is. **Don't place the antenna at a metal or carbon pole** but rather in a special plastic tube.
- If the receiver is connected to the battery to detect the battery voltage it can heat up (especially at 12 volt). Therefore **don't cover the receiver with foam**. Check the heat while taking your model for a test drive and ensure ventilation if necessary.

19. Tips for Mounting ESCs and Light Sets

- **Place power cables** to battery, motors and speakers **always as a pair** - + and - intertwined directly next to each other.
- Place servo and steering cables separately from the power cables **to avoid interferences**.
- Only **use interference suppressed motors**. Servonaut motors are all interference suppressed or delivered with suppression kit.
- Some modules heat up and therefore shouldn't be **covered in foam**. Check the heat while taking your model for a test drive and ensure ventilation if necessary.

20. Tips & Tricks

Adjusting the joysticks

Joystick length:

Hold lock nut, turn joystick head to the left to adjust it to the length you want. Screw the lock nut hand-tight to the left.

Spring, spring power, brake and ratchet:

Loosen the six screws to open the casing. Take the back off. A tip: There are two noses in the middle that latch into the front. Use a small tool to lift if necessary.

Adjust for each joystick separately (position the same, not mirrored):

Ratchet: Press the left brake spring down and screw it tight = joystick with ratchet

Brake: Press the right brake spring down and screw it tight = brakes

Spring: Screw to the right = no spring, to the left = spring

Spring power: Strength of the spring, screw to the right = more spring power

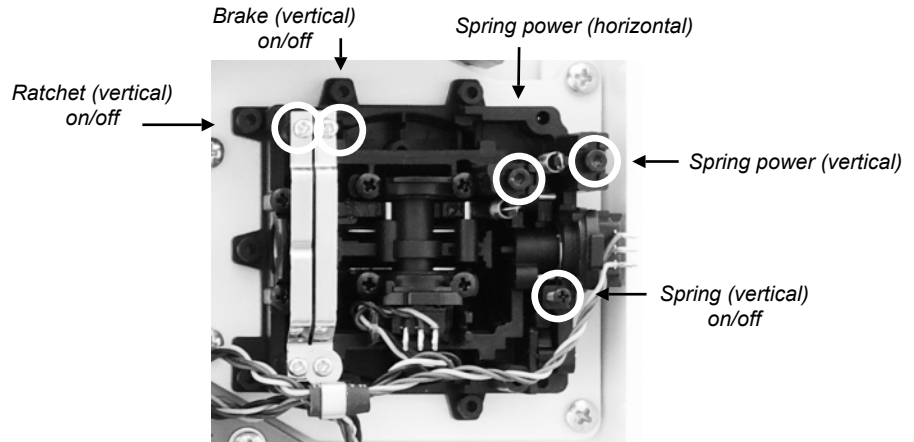

21. SD Card

[Menu] > [1v2] > [SD Card] on page 2

An SD Card slot is in your radio casing (SD Card included).

The SD Card has two functions:

- You can **save the radio configuration with all model settings**. You will receive a manual with the Update.
- Future **software updates** will be loaded from the SD Card to your radio as well. You will receive a manual how to update with the update itself.

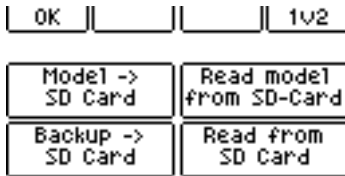

[Model -> SD Card]

Saves a single model to the SD Card. After pressing the key, you will see a list of models. The saved models can then be loaded on a different HS12. During the backup procedure, the first eight letters of the model name are used as file names. Spaces in the model name will be removed, any special characters will be replaced by and underscore '_'. Small letters will be converted to big ones. Two models with the names "Gmk 4001" and "GMK4001" will be saved as "GMK4001" on the SD Card. This

is really important to know, because in case a model already exists with the same name, it will be overwritten on the SD Card.

[Read model from SD Card]

Reads a model from the SD Card. After pressing the key you will see a list of models, which are saved on the SD Card. By pressing the key the corresponding model will be loaded to the HS12 internal memory. In the next step you can choose if you want to overwrite an existing model. If you choose not to overwrite an existing model, the loaded model will get a new unused model number as long as the total number of models is less than 15. In case 15 models are already set up in the radio, no model can be loaded from the SD Card. If you want to overwrite an existing model you can choose the model that will be overwritten from a list in the next step. For clarity the model number is displayed in front of the name.

Caution: If you load a model from a different HS12 the receiver data is not overwritten. In consequence the old model will still react to the radio. If you chose to overwrite a different model, you should rebind directly after loading.

Overwriting a model is especially useful if you use first and second radio with the newer receivers RX9, R6, R4. As you can copy a changed model from the first to the second radio without rebinding.

[Backup -> SD Card]

Performs a complete backup on the SD Card. This complete backup contains not only all models saved on the radio but also the radio settings. There can only be one complete backup on the SD Card. An already existing backup is overwritten automatically.

[Read from SD Card]

Loads a complete backup from the SD Card. This step should only be performed after consultation.

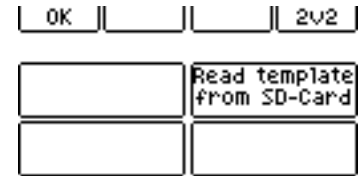

[Read template from SD Card] (page 2)

Enables installation of new templates in the radio. You can find these templates under [light set] when setting up a model.

[Delete model from SD Card] (page 2)

Shows a list of files on the SD Card and lets you delete them directly in the radio. This can especially be useful for some files that were written by radio software before version 2.3 which could sometimes not be deleted on a PC.

22. Software Update

If you have received a new official software version of the HS12 by Servonaut, you can proceed this way:

- First make sure your radio is charged sufficiently. You can control the charge status via the yellow menu key [Info].
- Turn off the radio.
- Open the housing.
- When you already have an SD-Card in your radio, remove it and copy the update file onto it.
- Make sure the SD Card you use is not locked (lock switch on the side). Insert the SD Card in the slot with the contacts facing down. The Card will then snap into place.
- Press both the red and green menu key at the same time and turn on the radio.
- Your radio shows the following information: "Datei gefunden. Prüfe Datei" which translates to: "Update: File found. Checking file..."

- Your radio shows the following information: "Update fertig. Sender abschalten" which translates to: "Update: Completed. Turn the radio off."
- You may turn the radio off and back on now.
- You can leave the SD-Card in the slot or use the previous Card.

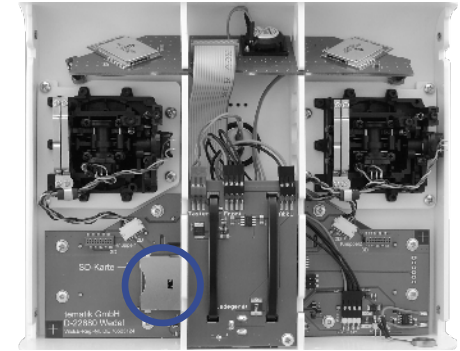

SD Card slot in the radio



Caution: Insert and remove Card only when radio is turned off!



Caution: Do not turn the radio off now!

23. Upgrade to 3D Joysticks

As an upgrade to your HS12 we offer a set with two 3D joysticks: the Zwo4StickSet3D. The 3D joysticks are **especially for construction machinery**, e.g. excavators and cranes because of the additional rotary knob.

With the 3D sticks you don't have the level switches - instead you use the push buttons on top of your sticks for switching between levels. In the [Menu] > [Radio] > [3D stick] you can select whether the push buttons act as momentary or memory switch - choose what you prefer for your functions.

The 3D sticks are easy to mount without soldering. Please see the manual that comes with your upgrade set for details.



Available as an accessory: Zwo4StickSet3D

24. Troubleshooting

The radio doesn't start?

Check the battery and recharge if necessary. Make sure the radio is switched off while charging.

The servos in the model don't react?

Press the red button [Model] and check if the model is displayed. If it is not visible check the receiver voltage in the model and the jumper of the receiver.

If it is displayed activate it with your radio. If the servos still don't react check if the servo channels are assigned to a control. See *chapter Quick Start*

You changed control settings but the changes don't have the affect you thought they would?

Check in the control menu if the same servo channel is assigned more than once to one control. Delete the multiple assignments.

Multiswitch decoder or multiswitch light set don't work correctly?

Remember that after activating a multiswitch on channel 7 or 8 the receiver needs to be bound again. See *chapter Menu Receiver*

Some decoder and light sets only check the signals after switching the model on. Make sure to replug the receiver channels only when the model is turned off if necessary.

If you adjust settings in the multiswitch menu always switch the model off and on again afterwards.

The receiver doesn't bind?

For binding the jumper of the receiver needs to be removed or replugged. See the manual of your receiver for details.

The servos on channel 7 or 8 twitch or don't react like they should?

Check in the multiswitch menu if the multiswitch function is activated accidentally.

The speed controller with teach-in function does not react as expected?

Make sure that the channel where the speed controller with automatic teach-in function is connected to, is assigned to a control.

The radio shows the following information: "Calibration values could not be loaded! Please recalibrate."

This report shows up when the 3D-Stick setting was changed without performing a new (joystick calibration)

Check if the setting "3D-Stick" is correct. ([Menu]>[Radio]>[3D Stick])

In case the setting is correct, you have to carry out a new adjustment with the control. You will find instructions in the manual for the 3D-Stick-Sets.

24. Glossary

Control

The term control stands for all control elements of your radio with which you can operate it - joysticks, buttons, softkeys (not the level switches).

Mode (change the assignment of the joysticks)

You can choose the assignment of controls to channels at the receiver freely. For a quick swap you can use the function [Menu] > [Radio] > [Control swap]. This functions allows you to swap all controls with each other even joystick function with softkey pair.

Dual-Rate (switch control travel)

If you want the control travel to be switchable you can use the level switches. This way you can make extensive adjustments because all settings and mixer functions can be switched. See *chapter Tips&Tricks and Mixer Functions - Dual Rate*

Reset (undo changes)

With the red button [Reset] you can set all settings in the control and channel menus back to default.

With the control outputs [Reset] first resets the inserted values. If they are already reset

pressing [Reset] a second time deletes the channel assignment for the current control output.

For the servo channels pressing [Reset] first resets the inserted values. If they are already reset pressing [Reset] a second time sets the channel type to [Servo].

Reverse (reverse direction of a control or channel)

The direction that a control affects e.g. a servo can be reversed in several menus. Select [Reverse] for a control and it changes all connected servo channels. If you select [Reverse] for the servo channel it only affects this one channel. You can also change the direction by adjusting the direction values for [Left/Down] and [Right/Up].



Tip: Adjust the direction for the servo channel so that the direction/function corresponds to the description [Left/Down] and [Right/Up]. Then you don't have to change it in the control menu.

Expo (change characteristics of the joysticks)

This function is only available for the joysticks and not for all control types. A negative expo value decreases the effect of small deflections and allows sensitive

steering.

A positive value on the other hand increases the effect of small deflections. In both cases the maximum deflection stays the same.

If you swap a joystick control with a softkey pair the expo adjustment disappears from the control menu. If you swap the controls back the expo adjustments are restored and active again.

Trim (adjust middle position of the controls)

The trim, the adjustment of the middle position for the joystick channels is far less used with truck models than with flying models. Therefore the softkeys are also used for trimming. See [Menu] > [Trim]. It's an alternative to use a softkey pair or the second level of a joystick. See *chapter Tips&Tricks*

Mixer Functions

While radios for flying use many preset mixers (not useful for vehicles) your Zwo4 HS12 has a universal and clear concept. Each control can affect up to three servo channels - one servo channel can be controlled by any number of controls. All necessary adjustments are accessible in the control menu so there is no need for a

special mixer menu. See *examples in chapter Mixer Functions*

Control filter

With this filter you can adjust the reaction time of a control. While adjusting the value first changes rapidly then a little slower.

 **Tip:** Filter values about 1,0 are ideal for realistic vehicle steering.

Servo speed

The speed determines how long it takes the servo to move from 0 to 100% deflection.

At a value of 0,0s to 0,1s the servo runs as fast as it can, the absolute speed depends on the type of servo. With a value larger than that it matches the actual time in seconds. The servo runs at constant speed not getting slower at the end like with the filter function for the control.

EPA End Point Adjustment (limit servo full deflection)

The maximum deflection of a servo (or the signal at an ESC) can be adjusted in the servo channel menu. It prevents that e.g. a servo reaches a mechanical stop and overloads.

The values for [Left/Down], [Right/Up] are adjustable between -150% and +150% (Exception pump: here the values are different). The values change and limit how far the servo moves. With a control value of

100% it always reaches the set maximum deflection. It doesn't exceed it even if several controls for this channel summed up are more than 100%.



Tip: Always adjust the mechanics first and only make small adjustments with your radio. If values under 80% seem to be necessary for a servo it is advisable to rethink the steering and place the rod further inwards at the servo. If the deflection causes problems in one direction only you can mount the steering arm a little rotated. Otherwise you lose torque / power!

Travel adjust (limit control deflection)

Each control has three outputs so it can affect three servo channels. The deflection for these outputs can be adjusted from -100% to +100% left and right. With 100% the servo channel reaches the set full deflection. As long as the control affects only one servo channel the control should be set to 100% and make all the adjustments at the servo channel. There you can increase the servo deflection to more than 100%.

Dead zone

Sets the range around the joystick center position in which the control value is 0% that is where the control doesn't react.

Valve backlash compensation [Backlash]

Hydraulic valves often need a certain deflection to react. With clearance compensation the hydraulic valves react directly even with small control movements.

25. Liability and Warranty / Disposal Instructions

This product is subject to the legal warranty requirements at the time of the purchase. The warranty does not cover damage due to incorrect handling like wrong battery connection or water damage. This warranty does not cover consequential, incidental or collateral damage under any circumstances. Liability is limited to the purchase price. By the act of using this product the user accepts all resulting liability.

Subject to change without notice. "Servonaut" is a registered trademark of tematik GmbH. All other product names, trademarks and company names are property of their respective owners.

tematik GmbH - Servonaut
WEEE-Reg.-Nr. DE76523124

02/2022

Software Version 2.3

Help us to protect the environment. Please do not dispose electrical and electronic equipment in domestic household waste.

As a distributor delivering devices, which contain batteries or accumulators, we are committed to advice you according to the battery regulation:

In some countries you are required by law to dispose of used batteries/rechargeable batteries not with domestic garbage but in accordance with the prevailing community regulations that apply to the disposal of batteries/electronics.

If there are no local regulations concerning battery/electronics disposal, please dispose of the device in a waste bin for electronic devices. Many electronics retailers now recycle batteries and other electronic components at no charge.





EU-Konformitätserklärung EU-Declaration of Conformity

Die Firma
The company

tematik GmbH
Feldstraße 143
D-22880 Wedel (Holst.)

bestätigt hiermit, dass das folgende Gerät
hereby confirms that the following device

Artikelbezeichnung: Handsender ServoNaut Zwo4 HS12

Article description:

Geräteklasse: 1

Equipment class:

den im folgenden angegebenen einschlägigen Bestimmungen entspricht
complies with the relevant provisions mentioned below

Elektromagnetische Verträglichkeit (EMV) – 2004/108/EC
Electromagnetic compatibility (EMC)

Harmonisierte EN-Normen
Harmonised EN-standards

EN 301 489-1 V1.9.2:2011

EN 301 489-17 V2.2.1:2012

Funkanlagen und Telekommunikationseinrichtungen – R&TTE 1999/5/EC
Radio and Telecommunication Terminal Equipment

Harmonisierte EN-Normen
Harmonised EN-standards

EN 300 328 V1.8..1:2011

Unterschrift / Signature

(Dipl.Ing. Jörg Völker)

Position:

Geschäftsführer / Managing Director

Ausstellungsdatum / Date of issue: 20.10.2016

27. Your notes



servonaut



tematik GmbH • Feldstraße 143 • D-22880 Wedel • sender@servonaut.de • Phone: +49 4103 / 808989-0